

# INSTALLATION, OPERATION AND MAINTENANCE INSTRUCTIONS

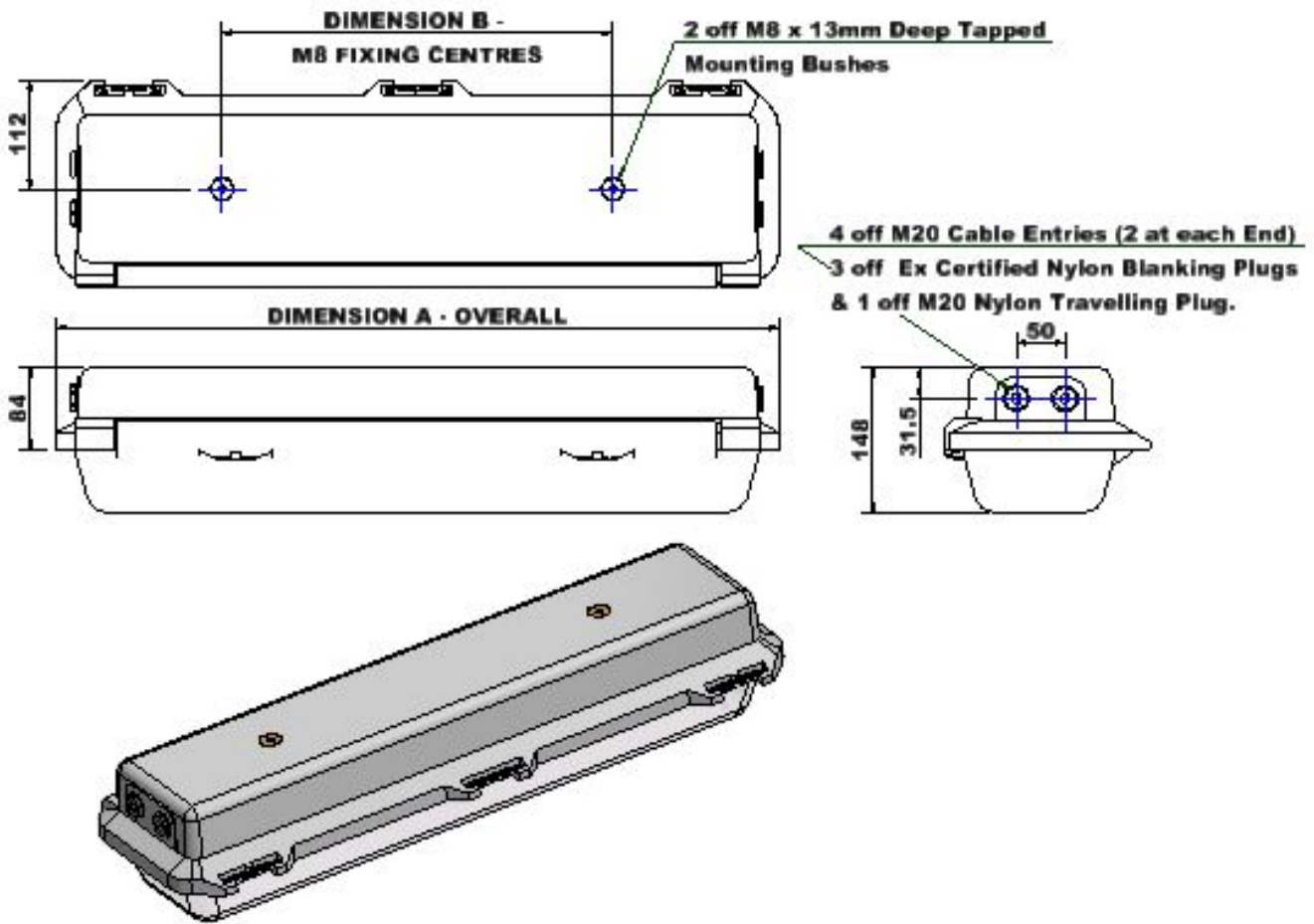

## Protecta III – LED Luminaires (Ex ec) ATEX, IECEx and UKEX

**Important:** Please read these instructions carefully before installing or maintaining this equipment. Good electrical practices should be followed at all times and this data should be used as a guide only.



MODEL SIZE	DIMENSION 'A'	DIMENSION 'B'
02L	742	400
04L	742	400
07L	1352	700



Type of Protection	Ex ec, (non-sparking). Ex tc,
Protection Standards	EN/IEC 60079-0, EN/IEC 60079-7, EN/IEC 60079-31
Area Classification	Zone 2 areas to EN/IEC 60079-10-1, Zone 22 areas to EN/IEC 60079-10-2.
Installation	EN/IEC 60079-14
Certificate	Type EC CML 21ATEX3109X Type Examination Certificate CML 21UKEX31271X IECEX Certificate of Conformity IECEX CML 21.0008X
Equipment Coding	Ex ec IIC T4 Gc Ex tc IIIC T75°C Dc, (ambient values see tables below for details)
ATEX/UKEX Coding	Ⓔ II 3GD
Ingress Protection	IP66/67 to EN/IEC 60529
  	<p>The CE marking of this product applies to "The Electrical Equipment (Safety) Directive", "The Electromagnetic Compatibility Directive", the "Waste Electrical and Electronic Equipment Directive" and the "Equipment and Protective Systems intended for use in Explosive Atmospheres Directive". [2014/35/EU, 2014/30/EU, 2012/19/EU and 2014/34/EU respectively].</p> <p>The UKCA marking of this product applies to "The Electrical Equipment (Safety) Regulations 2016", "The Electromagnetic Compatibility Regulations 2016", the "Waste Electrical and Electronic Equipment Regulations 2012" and the "Equipment and Protective Systems intended for use in Explosive Atmospheres Regulations 2016</p> <p>The Equipment is declared to meet the provisions of the ATEX directive (2014/34/EU) by reason of the Type Examination/EU Type Examination and meets the UK statutory requirements SI 2016 No.1107 and compliance with the Essential Health and Safety Requirements. M Poutney Technical Manager</p>

**1.0 Introduction - Protecta Zone 2 & 22 LED Luminaire**

The Protecta Safe Area LED Luminaires are surface mounted or suspended, utilising the two tapped holes on base of body, Normal operation is mains supply "ON" LEDS illuminated. They are mainly used in harsh environments and are constructed using a corrosion resistant glass reinforced polyester body attached to an injection moulded polycarbonate diffuser by hinges and a special clamp. The control gear and LED strips are mounted on a removable tray which for maintenance has hanging straps. Note: The ratings are listed in Tables A, B & C

**1.1 Application**

The luminaire is designed to be safe in normal operation. The luminaire should not be used where there are environmental, vibration or shock conditions above the normal for fixed installations. The gaskets should not be exposed to hydrocarbons in liquid or high concentration vapour states. The luminaire is suitable for applications where Category 3 apparatus can be used for Gas and Dust. The type examination does not address suitability for portable applications.

**2.0 Storage**

To optimise lifetime, luminaires should be stored in cool dry conditions preventing ingress of moisture and condensation between -25°C to +60°C

**3.0 Installation and Safety**

**3.1 General**

There are no health hazards associated with this product whilst in normal use. However, care should be exercised during the following operations. In the UK the requirements of the 'Health and Safety at Work Act' must be met.

Handling and electrical work associated with this product to be in accordance with the 'Manual Handling Operations Regulations' and 'Electricity at Work Regulations, 1989'. Your attention is drawn to the paragraphs (i) 'Electrical Supplies', (ii) 'Electrical Fault Finding and Replacement' and (iii) 'Inspection and Maintenance'. The luminaires are Class 1 and should be effectively earthed.

The information in this leaflet is correct at the time of publication. The company reserves the right to make specification changes as required.

The polycarbonate diffuser presents a potential source of ignition by **electrostatic electricity**. The diffuser should only be cleaned using a damp cloth. The luminaire should not be mounted very near to any probable location of fast-moving stream of dry air, steam etc. which could generate a propagating brush static discharge.

### 3.1.1 Use in Combustible Dust Atmospheres – Zone 22

Where the equipment is used in ignitable dust atmospheres reference must be made to the selection and installation standards in order that the equipment is used correctly. In particular this applies to the de-rating of surface temperature for use where dust clouds may be present. Dust layers should not be allowed to accumulate on the fitting surface and good housekeeping is required for safe operation. Dust in layers has the potential to form ignitable clouds and to burn at lower temperatures.

Refer to EN (IEC) 60079-10-2 & EN (IEC) 60079-14 for additional details of selection and installation.

### 3.1.2 Hybrid Mixtures – Gas plus Dust.

Where Hybrid mixtures exist as defined in EN1127 as a potentially explosive atmosphere, consideration should be given to verifying that the maximum surface temperature of the luminaire is below the ignition temperature of the hybrid mixture.

### 3.1.3 Cleaning

The body of the luminaire may be cleaned with a mild solution of household detergent and water, after cleaning the body should be washed and wiped with clean water. The diffuser should not be polished or wiped with a dry cloth, as a risk of explosion due to electrostatic discharge may result. Cleaning of the diffuser with any chemical or hydrocarbon solvent-based cleaner may result in severe damage.

### 3.1.4 Aggressive substances

If the equipment is likely to come into contact with aggressive substances, then it is the responsibility of the user to take suitable precautions that prevent it from being adversely affected, thus ensuring that the type of protection provided by the equipment is not compromised.

Aggressive substances: e.g. acidic liquids or gases that may attack metals or solvents that may affect polymeric materials.

Suitable precautions: e.g. regular checks as part of routine inspections or establishing from the material's data sheets that it is resistant to specific chemicals.

## 3.2 Tools

12mm, 5mm and 3mm flat blade screwdriver. Pozi number 2 screwdriver

Suitable spanners for installing cable glands. Pliers, knife, wire strippers/cutters.

## 3.3 Electrical Supplies and Control Gear

Luminaires fitted with electronic control gear are suitable for a rated supply from 120- 277Vac 50-60Hz,

The safety limits are +10% of this. The supply would normally be expected to lie within +/-6% of rated. The LED supply is regulated, therefore the light output over the range is substantially unchanged.

The driver can also utilise DC voltage (127-250Vdc 02L) 127-300Vdc for 04L and 07L.

Electronic gear has integrated power factor correction to >0.90.

**Warning:** *Luminaires are assessed and/or tested for EMC requirements. This is based on the disposition of entry cables and, where appropriate, through wiring arrangements as supplied or specified. Users must take care not to introduce wiring into parts of the apparatus materially different to that which could be reasonably inferred from the disposition of fixed supply terminals and specified wiring.*

## 3.4 Light Emitting Diodes (LED)

LED's are supplied in either 2000, 4000 or 7000 Lumen options with the colour temperature of 3000K,4000K or 5000K.

### 3.4.1 Dimming Option

If the product has a /DM suffix this means it comes fitted with a dali dimmable ballast.

2 additional cable cores are needed to run the DALI data cable to DALI switch or PC with compatible software and hardware.

### 3.5 Mounting

Luminaires should be installed where access for maintenance is practical and in accordance with any lighting design information provided for the installation. The standard suspension is via two M8 tapped holes in stainless steel bushes moulded into the top of the body, the recommended torque for the fixing bolts is 10-15Nm. (at 400mm centres for 02L and 04L and 700mm centres for the 07L model).

Various adaptors, pole clamps and suspension brackets are available to order.

### 3.6 Cable Connection

#### 3.6.1 Cables

The temperature conditions of the supply cable entry point are such that 70°C (ordinary PVC) cable can be used. 300/500V cable ratings are adequate and no special internal construction is necessary. Where MCB's are used, the type with the higher short time tripping current ratio used for motor starting and lighting should be specified. The standard maximum looping size is 4mm<sup>2</sup> with 2.5mm<sup>2</sup> through wiring.

#### 3.6.2 Cable Gland Types

The installer and user must take responsibility for the selection of cables, cable glands and seals.

The product is certified for ATEX, IECEx and UKEX and to comply with the certification for installation cable glands and sealing plugs must be ATEX, IECEx or UKEX certified depending on site requirements.

Cable glands for entry into Ex enclosures when fitted with any gland to body sealing method and supply cable, must reliably maintain the IP rating of the enclosure with a minimum value of IP66 / 67 or IP6X for conductive dust. Nylon washers are provided with the unit to seal between the gland body and the luminaire. For installation outside the EU suitable cable glands in accordance with IEC 60079-0 will meet the technical requirements. Four entries are provided on the standard model. Three entries are fitted with suitably approved blanking plugs, the fourth entry with a transit plug that is not suitable for use in service. M20 x 1.5 entries are standard, other sizes are available on request. The standard entry configuration is with an earthed metal plate with tapped holes mounted in the body. Where brass cable glands are to be installed, cadmium or nickel plating should be used.

#### Special Conditions:

**All unused cable entries must be fitted with a blanking element. The permitted component certified blanking elements for this range of luminaires are listed on the certificate.**

### 3.7 Electrical Connections

For the standard mains incoming terminal block, the through current rating is 16A. 4mm<sup>2</sup> terminals are standard. Luminaires fitted with Weidmuller MK6 (Marked - IECEx TUR18.0019U) are suitable for 26A max current rating and 6mm<sup>2</sup> cable.

Luminaires fitted with Wago Type 262 (Marked - IECEx PTB.04.0004U) are suitable for 30A max current rating and 4mm<sup>2</sup> max cable.

Screw type or screw-less "cage clamp" terminals are fitted in the range of luminaires. Mains terminal blocks are marked L N Earth.

#### 3.7.1 Installation of HF

Following the mounting of the apparatus and the connection of the supply cable the unit **cannot** be insulation tested. After commissioning the unit can be shut down for a long period without loss of function.

### 3.8 Servicing and Operation

#### 3.8.1 Opening and Closing the Cover

The procedure for opening the cover is as follows:

Insert the tool into one of the slots in the clamping bar with the end of the tool located into the outer flange of the body as a fulcrum point, a wide blade screwdriver is recommended. Gently lever the tool away from the diffuser, the clamping bar will begin to open. Insert the tool in the other clamping bar slot and gently lever away from the diffuser the clamping bar will open and the cover will be retained by the hinge. Should difficulty be experienced reinsert the tool in the first slot and repeat the procedure.

The procedure for closing and securing the cover is as follows:

Ensure the hinge mechanism is clear of any obstruction and then swing the diffuser into the closed position. Support the diffuser in position whilst pushing the clamp bar over the edge of the diffuser. Apply even pressure at both ends of the bar and press the bar over centre.

### **3.8.2 Removal and Replacement of Clamping Bar (if required)**

Open the luminaire as above and remove the diffuser or let it swing down. Press the clamping bar towards the closed position, tip forward beyond the closed position and the clamping bar will be released from the body. To replace the clamping bar, put in position on the body with the front edge pointing as far inwards as it will go. Click the bar outwards and bring back to the normal closed position. The clamping bar should then be secured in position, open the clamping bar fully by using hand or screwdriver pressure (avoid damaging the gasket), the clamping bar is then ready to accept the normal closure of the diffuser.

### **3.8.3 Releasing the LED Tray / Gear Tray**

Loosen the four fixing screws retaining the LED / Gear tray and slide over keyhole slots. The tray will hang on the retaining cords without stressing the wiring between body and tray. Replace in reverse order.

### **3.8.4 Retro Fitting Lamps to LED's**

Before opening the front cover ensure that the luminaire is isolated from the mains supply. Access for retro fitting is via the front cover, care is to be taken as there is limited suspension of the cover. Make sure that the correct ESD protection is taken during LED replacement to avoid electric discharge to the PCB.

### **3.8.5 Commissioning**

Energise the mains and check that LED's illuminate when the supply is energised.

## **3.9 Inspection and Maintenance**

**Important:** *Isolate the mains supply and disconnect the battery terminal before carrying out any work.*

### **3.9.1 Replacement of Electronic Ballast**

System life > 120,000hrs

Therefore, replacement of this component should be unnecessary. The electronic ballast contains no replaceable parts. Should it be found necessary to replace this part, the following procedure should be adopted: Ensure that the Luminaire is isolated from mains (and battery supply, if Inotec module is being utilised), otherwise a risk of shock may occur. Disconnect the leads on the ballast at the terminal block. Undo the ballast securing screws and washers and withdraw the ballast from the gear body. Replace in reverse order.

### **3.9.2 Routine Examination**

The Luminaire must be de-energised before opening. Individual organisations will have their own procedures. What follows are guidelines based on our experience:

- 1 Ensure LED's are lit when energised by mains supply.
- 2 Visually check diffuser cover for damage, this should only be cleaned using a damp cloth to avoid static, and only use recommended detergents for polycarbonate. If the polycarbonate is discoloured or damaged a new diffuser cover must be fitted.
- 3 When de-energised and left to cool, there should be no significant sign of internal moisture. If there are any signs of water ingress, the Luminaire should be opened, dried and any likely ingress points eliminated by re-gasketing or other replacements.
- 4 Check cable glands for tightness and nip up if required.
- 5 Check any external and internal earths.
- 6 Check all terminations are firmly screwed down, tighten if necessary.
- 7 Check clips visually for any damage and replace, if necessary.
- 8 If it has been suspected that the Luminaire has suffered mechanical damage, a stringent workshop check on all components should be made. All components can be removed from the Luminaire for inspection.

**4.0 Electrical Fault Finding and Replacement**

The supply must be isolated before opening the Luminaire.

Any live fault finding must be done by a competent electrician and, if carried out with Luminaire in place, under a permit to work.

The control gear can be tested for continuity of connections with a low voltage tester.

If LED's go out repeatedly, and replacement components do not work or expected life is reduced, the control gear should be returned for replacement / testing.

On re-assembly all faulty / damaged wiring should be replaced, and connections checked.

**5.0 Disposal of Material**

The unit is made from combustible materials. The control gear contains plastic parts and polyester resin. All electrical components and the body parts may give off noxious fumes if incinerated. Take care to render these fumes harmless or avoid inhalation. Any local regulations concerning disposal must be complied with. Any disposal must satisfy the requirements of the WEEE directive [2012/19/EU and Regulations 2012 ] and therefore must not be treated as commercial waste. The unit is mainly made from incombustible materials.

**5.1 LED's**

LED's in modest quantities are not "special waste". They should be broken up in a container to avoid injury. Avoid inhaling dust.



To comply with the Waste Electrical and Electronic Equipment directive 2012/19/EU and Regulations 2012 the apparatus cannot be classified as commercial waste and as such must be disposed of or recycled in such a manner as to reduce the environmental impact.

TABLE A - SCHEDULE – LED CONTROL GEAR – NON-EMERGENCY – 120 to 277Vac – 127 to 300Vdc					
Note: for Dust Ratings Refer to Max Surface Temperatures.					
Product code	Body Type	Nominal Volts	Ambient Temperature	T Rating	Max Surface Temperature (Dust)
PR3C/02L/LE	2ft Twin	120-277Vac 127-250Vdc	-40°C ≤ Ta ≤ +55°C	T4	75°C
PR3C/04L/LE	2Ft Twin	120-277Vac 127-300Vdc	-40°C ≤ Ta ≤ +55°C	T4	75°C
PR3C/07L/LE	4Ft Twin	120-277Vac 127-300Vdc	-40°C ≤ Ta ≤ +55°C	T4	75°C

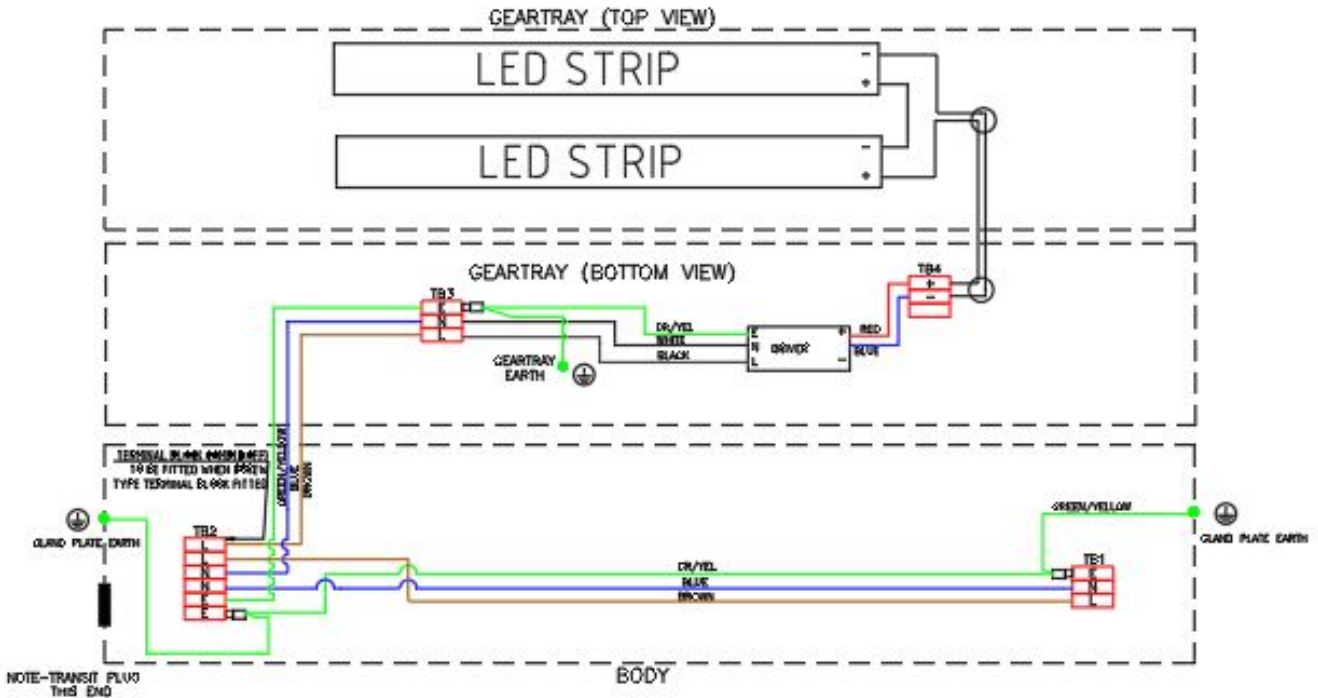

Table B		Series Standard circuit			Refer to Section: 1.0	
No. of LED strips	Lumens	Driver Current	Power Consumption Watts	Line Current	Inrush Current/ Duration	
02L 1 x 560mm	2296	400mA	15	0.06-0.13A	36A (2.1 μs)	
04L 2 x 560mm	3526	300mA	23	0.09-0.2A	34A(2.3 μs)	
07L 2 x 1120mm	6596	600mA	44	0.16-0.38A	36A (2.7 μs)	

### Typical Standard 04L LED Wiring Diagram





Note: For other Wiring Diagrams, please contact the manufacturer

Chalmit Lighting is a leading supplier of Hazardous Area lighting products

	<p><b>CHALMIT LIGHTING</b>          PO Box 5575          Glasgow, G52 9AP          Scotland</p>	
<p>Telephone: +44 (0) 141 882 5555          Fax: +44 (0) 141 883 3704          Email: info@chalmit.com          Web: www.chalmit.com</p>	<p>Registered No: 669157          Registered Office: Cannon Place          78 Cannon Street          London EC4N 6AF UK</p>	

For technical support, please contact: techsupport@chalmit.com

Note: Chalmit Lighting reserves the right to amend characteristics of our products and all data is for guidance only.

	<b>EU/UK-Declaration of conformity</b>		
	<b>UE-Déclaration de conformité</b>		
	<b>EU-Konformitätserklärung</b>		
Manufacturer	Chalmit	Address	388 Hillington Road, Glasgow. G52 4BL Scotland UK
Product	Protecta III LED Non-Emergency		
Notified Body	CML B.V. 2776		
Type Examination Certificate	CML 21ATEX3109X		
Approved Body	Eurofins CML 2503		
Type Examination Certificate	CML 21UKEX31271X		
ATEX/UKEX Coding	 II 3 GD		
ATEX/UKEX Classification	Group II Category 3 GD		
Equipment Coding	Ex ec IIC T4 Gc, Ex tc IIIC T75°C Dc		
Ingress Protection	IP66/67		
The technical basis, with respect to equivalence of			
La base technique, en ce qui concerne l'équivalence de			
Die technische Grundlage hinsichtlich der Normen			
Protection Standards EN 60079-0, EN 60079-7, EN 60079-31			
Area Classification EN 60079-10-1, EN 60079-10-2.			
of compliance with the EHSRs is valid as there are no changes which materially affect the state of technological progress of the product.			
en conformité avec les EESS est valide puisqu'il n'y a aucun changement qui affecte matériellement l'état de l'évolution technologique du produit.			
zur Erfüllung der GSGA ist gegeben, da keine Änderungen erfolgt sind, die einen Einfluss auf den technischen Stand des Produkts haben.			
Terms of the directive:		Standard & Date Certified to	Standards Date Declared to
Prescription de la directive:		Standard & date certifiée à	Normes date Déclaré
Bestimmungen der Richtlinie:		Standard & Datum Zertifiziert nach	Standards Datum erklärt
2014/34/EU SI 2016 No.1107	Equipment and protective systems intended for use in potentially explosive atmospheres.	EN 60079-0: 2018 EN 60079-7: 2015 +A1:2018	
2014/34/UE	Appareils et les systèmes de protection destinés à être utilisés en atmosphères potentiellement explosibles.	EN 60079-31: 2014	
2014/34/EU	Geräte und Schutzsysteme zur bestimmungsgemäßen Verwendung in explosionsfähigen Bereichen.		
2014/30/EU Regulations 2016	Electromagnetic compatibility	EN 55015 : 2019	
2014/30/UE	Compatibilité électromagnétique	EN 61547 : 2009	
2014/30/EU	Elektromagnetische Verträglichkeit	EN 61000-3-2 : 2019	
2014/35/EU Regulations 2016	Low voltage equipment	EN 60598-1 : 2015	
2014/35/UE	Équipements électriques à bas voltage	EN 60529 : 1992+A2:2013	
2014/35/EU	Niederspannungsgeräte / -systeme		
2012/19/EU Regulations 2012	Waste of electrical and electronic equipment		
2012/19/UE	Déchets d'équipements électriques et électroniques		
2012/19/EU	Entsorgung der elektrischen und elektronischen Geräte / Systeme		





2011/65/EU Regulations 2012	RoHS II Directive		
-----------------------------	-------------------	--	--

On behalf of the Chalmit, I declare that, on the date the equipment accompanied by this declaration is placed on the market, the equipment conforms to all technical and regulatory requirements of the above listed directives.

En tant que représentant du fabricant Chalmit, je déclare qu'à la date où les équipements accompagnant cette déclaration sont mis sur le marché, ceux-ci sont conformes à toutes les dispositions réglementaires et techniques des directives énumérées ci-dessus.

Hiermit bestätige ich, im Namen von Chalmit, dass am Tag der Lieferung des Produkts/der Produkte zusammen mit dieser Erklärung das Gerät/die Geräte alle technischen und regulativen Anforderungen der oben aufgeführten Direktiven erfüllt.

Name and Date Mark Poutney 17/01/2022  
 Nom et Date  
 Name und Datum

Technical Manager  
 Directeur technique  
 Technischer Leiter

Quality Assurance Notification by: **SGS Fimko OY 0598**  
 Notification d'assurance qualité par: **0598**  
 Qualitätssicherungsnotifikation durch:

Quality Management System Accreditation:  
 Système de Management Qualité Accréditation:  
 Qualitätsmanagementsystem Akkreditierung:  
 Environmental Management System.  
 Système de gestion de l'environnement.  
 Umwelt kontroll system.

**ISO 9001**

**ISO 14001**  
 by/par/durch  
**Lloyd's Register**  
**LRQ 4005876**

UKCA Quality Assurance Notification by: **SGS Fimko OY 10598**

**Certificate No./Certificat N°/Zertifikat Nr.**